

VICUT
ANHUI WILLIAM CNC TECHNOLOGY CO.,LTD

XY Trimmer

User manual



Catalogue

1、 Appearance-----	2
1.1 Machine descriptions-----	2
1.1.1 Mounting the pedestal-----	2
1.1.2 Motherboard wiring details-----	4
2、 Description-----	5
2.1 Introduction of the screen-----	5
2.1.1 Mark screen-----	5
2.1.2 Length screen-----	7
2.1.3 Setting screen-----	8
2.1.4 More options screen-----	9
2.2 Using-----	10
2.2.1 Operation-----	10
2.2.2 Software-----	12

Appearance

1.1 Machine descriptions

1.1.1 Mounting the pedestal

① BOM view

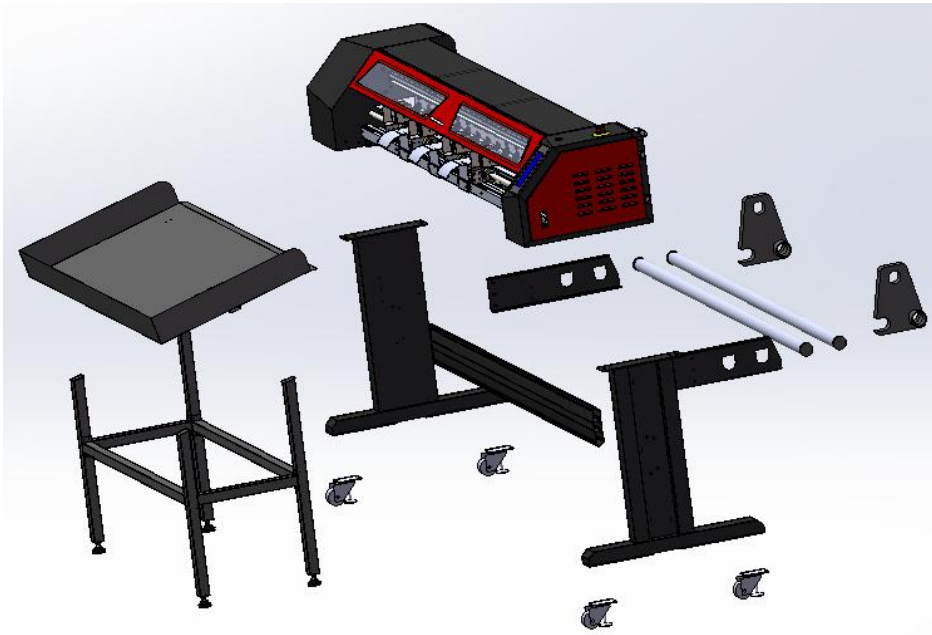

② Install the pedestal

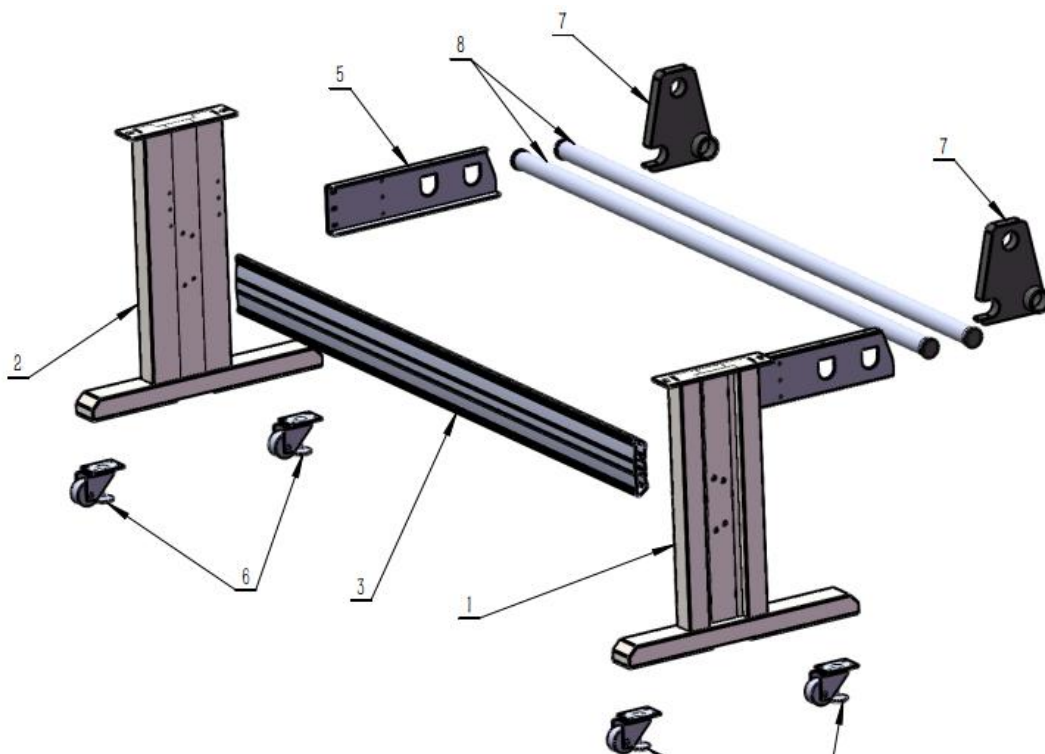

③ Install the paper tray

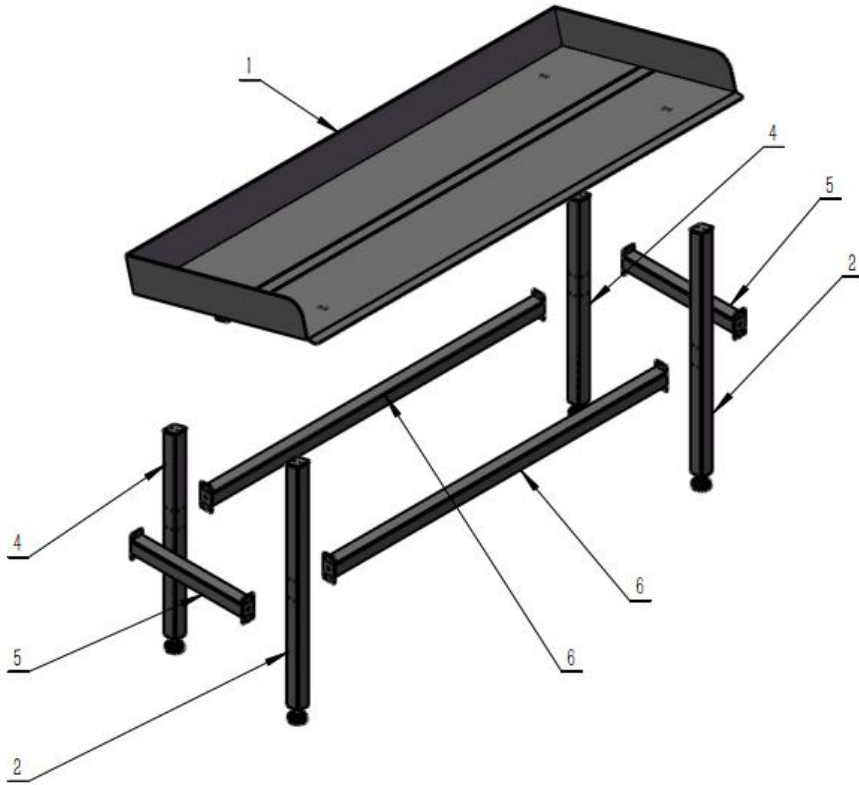

④ The whole view

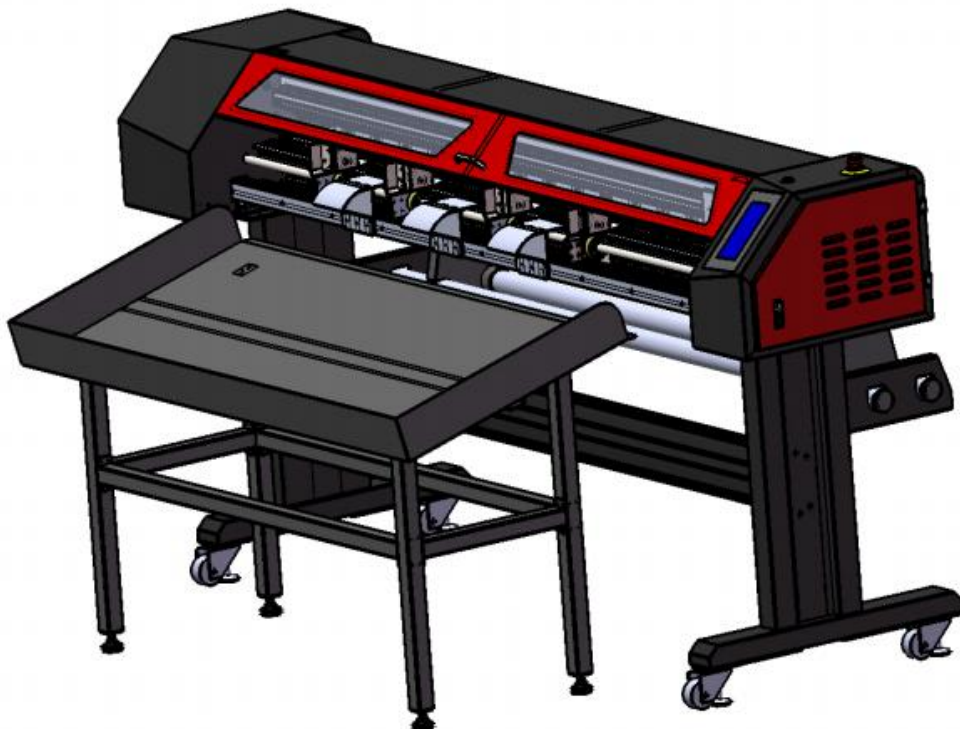

1.1.2 Motherboard wiring details

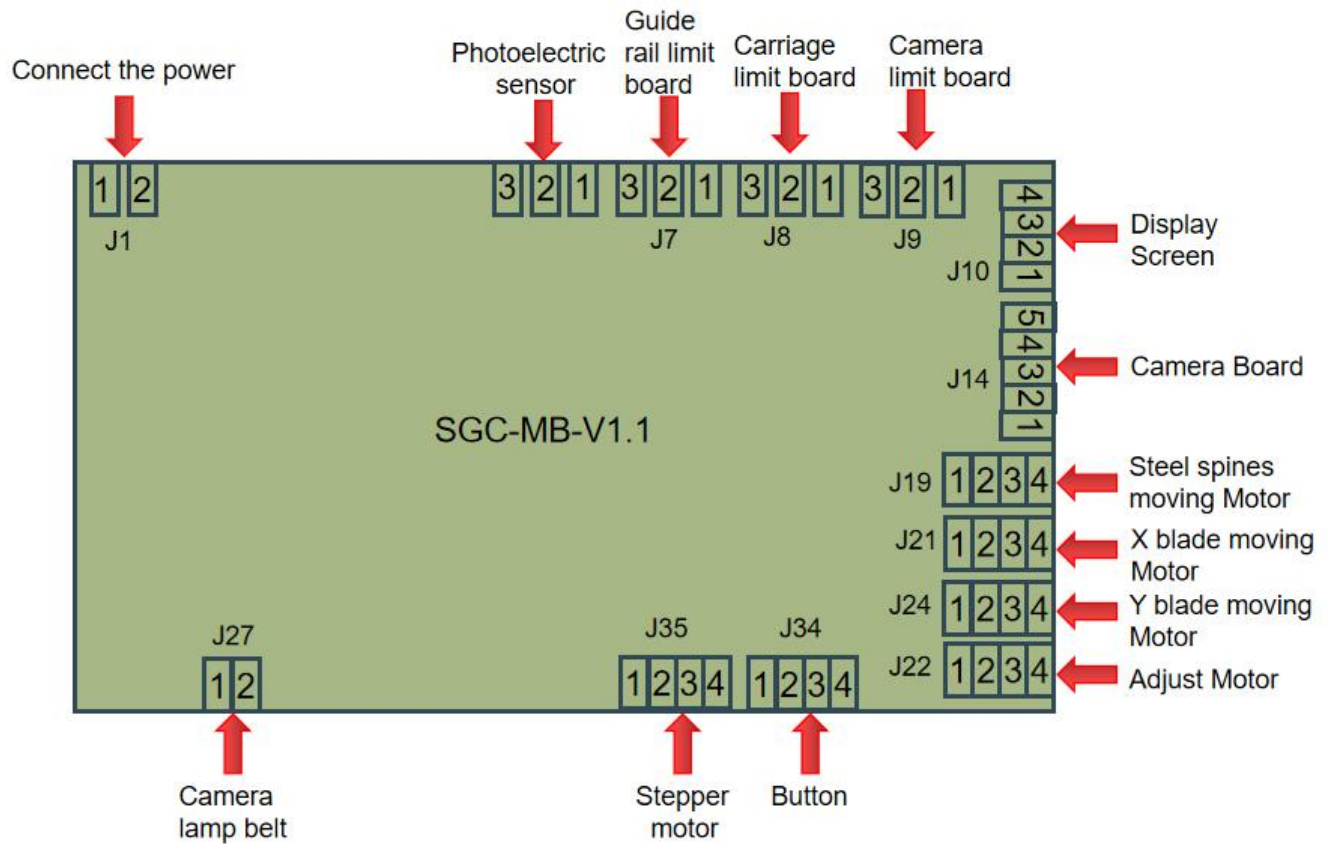

Attention:

- 1、 Confirming the port number are matched when connecting the wire in case of parts or machine damage caused by wrong wiring.
- 2、 When you need to replace the mainboard or motor, please take contact with our sales.

Description

2.1 Introduction of the screen

2.1.1 Mark screen

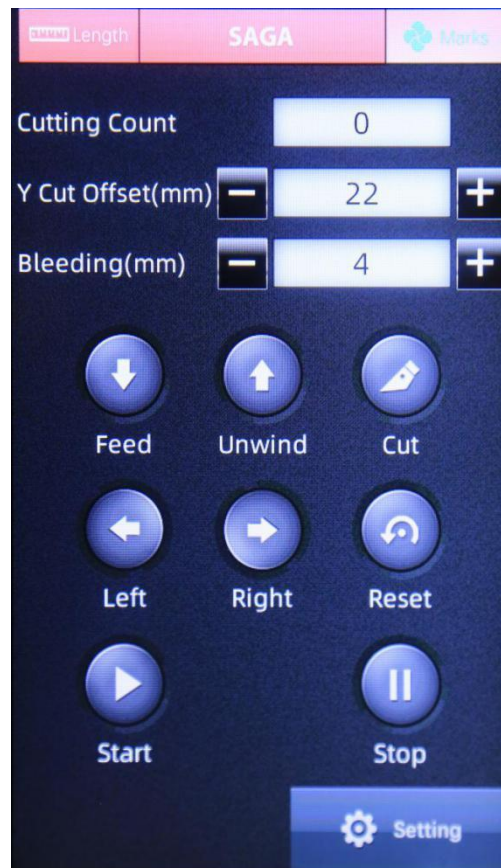

- ①Cutting count:The value is times that have cut;
- ②Y offset:Each 1mm means 4 numerical values.Enter “+” to plus,enter “-”to reduce.
- ③Cutting width:The bleeding between two photos.
- ④Descriptions of keys:
 - Feed: Enter the material.
 - Unwind: Back the material.
 - Cut: Cut the material.

- Left: Move to the left.
- Right: Move to the right.
- Reset: Back to the initial point.
- ⑤ Start: Start to cut.
- ⑥ Stop: Pause the cutting.
- ⑦ Setting: Enter the setting screen (Modify the X、 Y movement speed).

2.1.2 Length screen

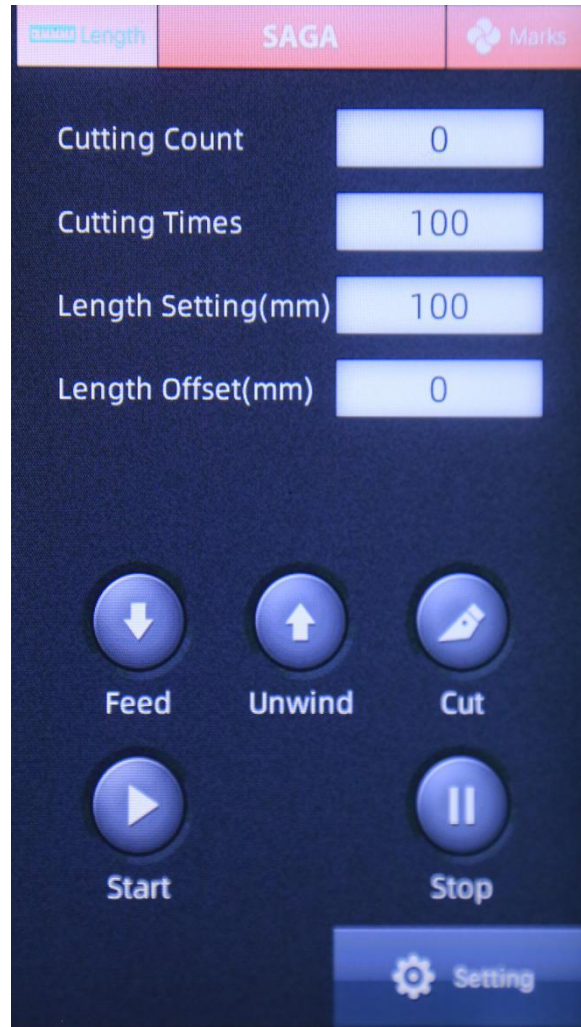

- ①Cutting count:The times that have cut.
- ②Set the cutting times:The cutting times you need.
- ③Cutting length:The feeding length
- ④Length offset:Each 1mm represent 4 numerical value.Over plus,less reduce.

2.1.3 Setting screen



- ①Count:Times that have cut.
- ②X speed:Feeding speed.(Three patterns to choose.)
- ③Y speed:Horizontal speed.(Three patterns to choose.)
- ④More options:Enter next screen.

2.1.4 More options screen

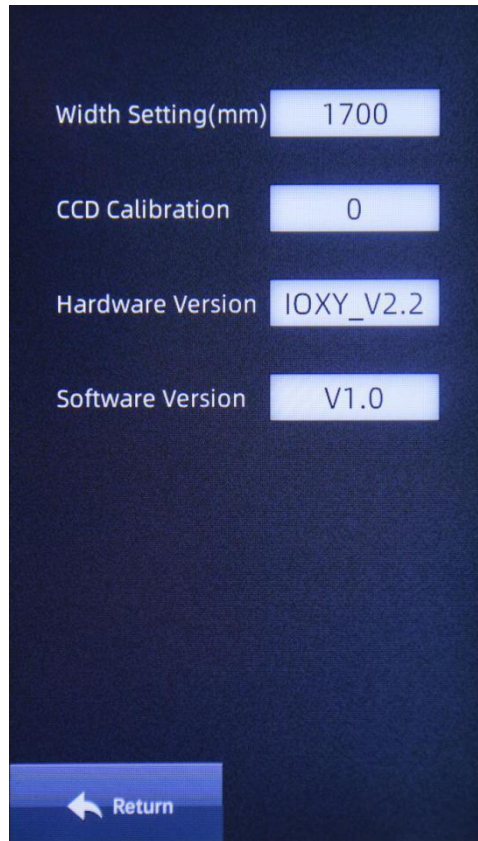

- ① Machine width:Cutting width in Y direction.
- ② CCD calibration:Scan the mark to show the value.(10 by default)
- ③ Hardware version:Hardware version number.
- ④ Software version:Software version number.

2.2 Using

2.2.1 Operation

- ① Fix the printed materials on the paper fixator. Let the material through the machine from front to rear.



- ② Adjust the media set lever according to the material position after feeding.

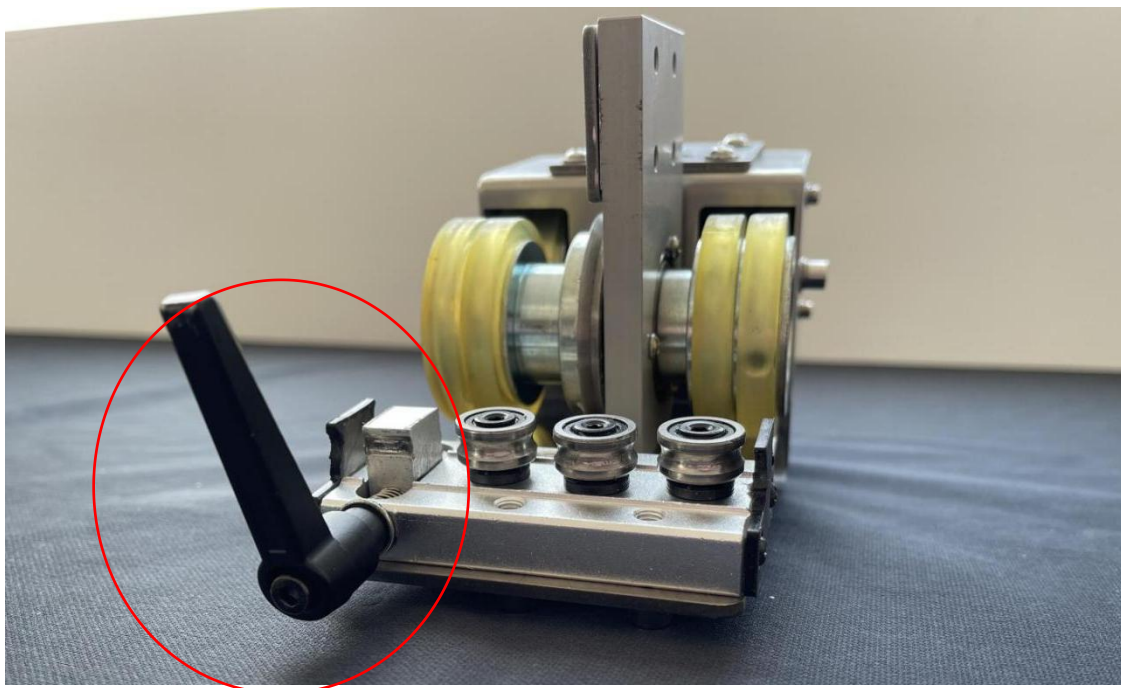

③ Align the blade to the material. Operate and cut.

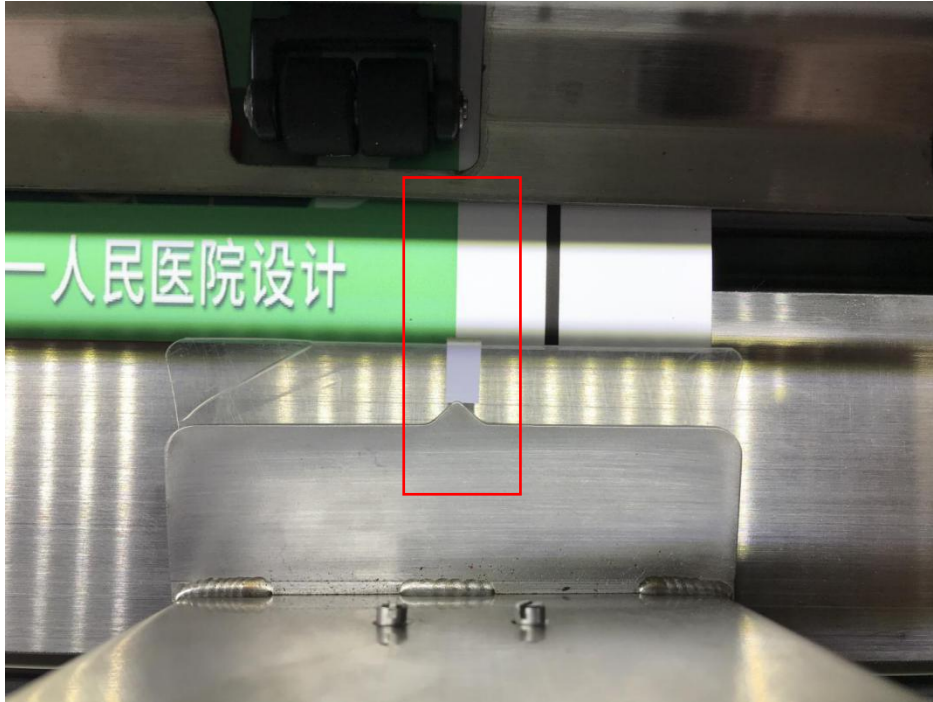

④ Adjust the screw nut when add the blade.

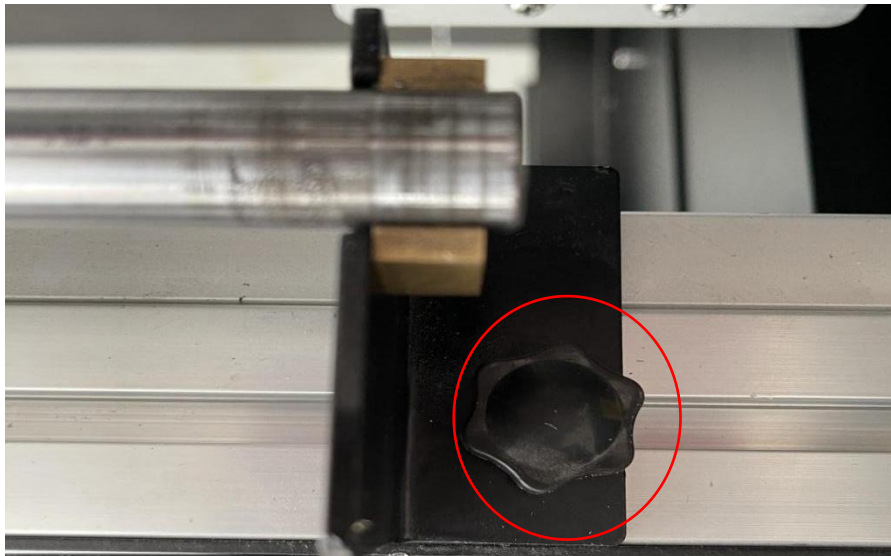

2.2.2 Software

① Import the photograph to Maintop. After completing the typeset. Click the right key, choose “SAGA cut guide line” .

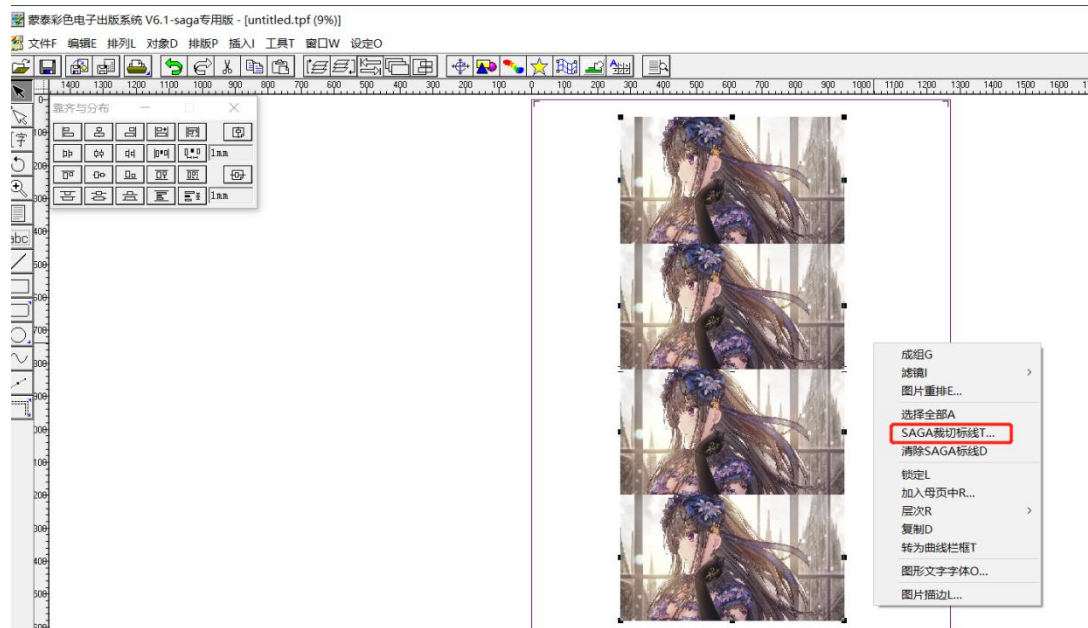

② Trimmer pattern--XY trimmer pattern, choose the left guideline or right guide line in demand.

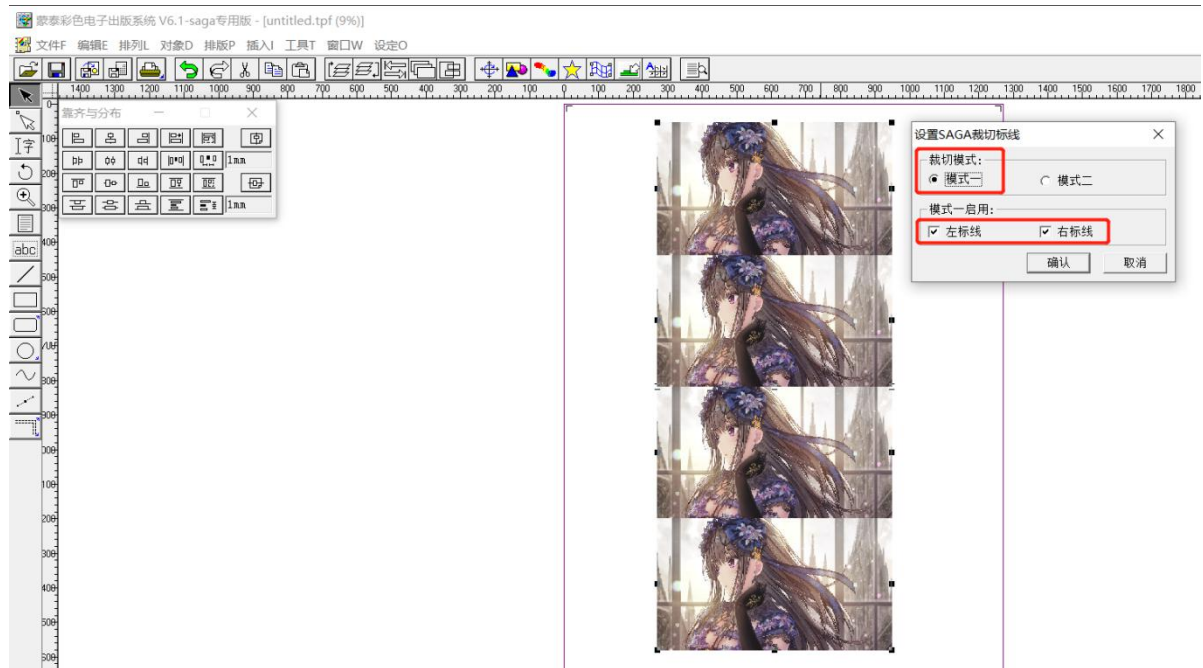

③After completing,print it and cut.

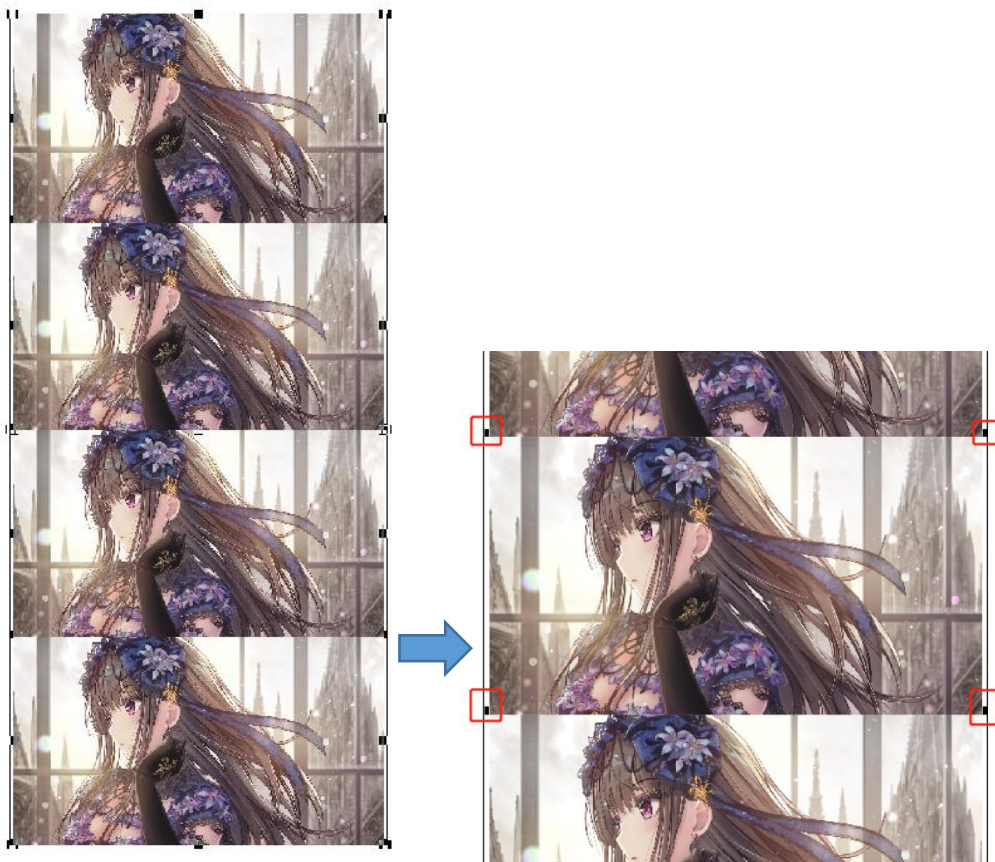

Attention:

- 1、 We only demonstrate how to create the mark code. More details about Maintop please go to Maintop website.
- 2、 The print effect depends on the photograph. Confirm the photo before printing.